

MASSEY VICTORY HEIGHTS RESIDENTS ASSOCIATION

General Meeting April 16 , 2026



GARAGE SALE

TIME TO REGISTER FOR:



Agenda

Welcome & Land Acknowledgement

Main Presentation / Speakers

Current status and forth coming changes regarding the City's Infill housing accelerator program and the effects on the Massey Victory Heights area. WITH

Lynn Roxburgh, Manager Housing and Land Use Planning
City of New West

Other Speakers / Announcements

John Cooke , Realtor and MVHRA Sponsor
Heritage New Westminster , **Deane Gurney**, HNW President

Miscellaneous Announcements



Agenda continued

General Q & A & Miscellaneous Announcements

- Meeting with NWPD and RA's on March 26th
 - Mobility Lanes (Bike Lanes) Phase 3
 - Street Light Upgrade Work





Massey Victory Heights Residents Association recognizes and acknowledges the Qayqayt First Nation, as well as all Coast Salish peoples, on whose traditional and unceded territories we live, we learn, we play and we do our work

- Home
- Advocacy
- Contact Us
- About Us
- Sponsors
- Meetings
- Events
- Newsletter
- Media
- Sign Capper
- Forms
- Parks
- Little Libraries

Massey Victory Heights Residents Association Advocating On Local Neighbourhood Issues

Click individual Title Bars Below For Details on Each Issue

- [Active Transportation Plan \(Bicycle Routes\)](#)
- [Neighbourhood Lighting Upgrade](#)
- [Heritage New West advocating for a better balance between preservation re MVH stree lighting replacement program](#)
- [New Advanced Meter Infrastructure \(AMI\) \(Elect Smart Meter\)](#)
- [Residents Association Forum meeting with all RA presidents and Mayor](#)

Community Policing Committee Mtg with RA President and NWP Community Engagement Department:

- **March 26, 2026**
[Minutes](#) from NWDP meeting with RA's
- **October 2, 2025**
[Minutes](#) from NWDP meeting with RA's



New Westminister Police Department

New Westminister Police Department
Community Policing Committee Meeting Minutes
March 26th 2026 – In Person and Virtual





New Westminster Police Department

New Westminster Police Department
Community Policing Committee Meeting Minutes
March 26th 2026 – In Person and Virtual

Questions:

- Q: Specifically regarding traffic incidents that have been reported over the last three years:
- 1) that are falling within 8th Ave to 10th Ave, and from Cumberland Street to Richmond Street .
 - 2) traffic incidents that have occurred along the length of Churchill Street
 - 3) traffic incidents that have occurred at the intersection of Churchill Ave & Massey Street
 - 4) traffic incidents that have occurred at the intersection of Churchill Ave & Chilliwack Street
 - 5) traffic incidents that have occurred at the intersection of Chilliwack Street & Chestnut Street
 - 6) traffic incidence at the intersection of York Street and 8th Ave



Questions:

- Q: Specifically regarding traffic incidents that have been reported over the last three years:
- 1) that are falling within 8th Ave to 10th Ave, and from Cumberland Street to Richmond Street .
 - 2) traffic incidents that have occurred along the length of Churchill Street
 - 3) traffic incidents that have occurred at the intersection of Churchill Ave & Massey Street
 - 4) traffic incidents that have occurred at the intersection of Churchill Ave & Chilliwack Street
 - 5) traffic incidents that have occurred at the intersection of Chilliwack Street & Chestnut Street
 - 6) traffic incidence at the intersection of York Street and 8th Ave

Primary UCR	2023	2024	2025	Total
COLL-DMGE<10000	6	6	8	20
100 BLOCK E 10TH AVE	1			1
300 BLOCK CHURCHILL AVE		1		1
300 BLOCK E 8TH AVE	1		1	2
CUMBERLAND ST / E 8TH AVE	2	1		3
E 10TH AVE / CARIBOO RD			1	1
E 10TH AVE / CHILLIWACK ST			1	1
E 10TH AVE / CUMBERLAND ST		1		1
E 8TH AVE / CUMBERLAND ST		2	3	5
E 8TH AVE / YORK ST		1		1
RICHMOND ST / E 8TH AVE	2		2	4
COLL-DMGE>10000	4		4	8
300 BLOCK E 10TH AVE	1			1
CARIBOO RD / E 10TH AVE	1			1
CUMBERLAND ST / E 8TH AVE	2		1	3
E 8TH AVE / CUMBERLAND ST			1	1
MASSEY ST / CHURCHILL AVE			1	1
RICHMOND ST / E 8TH AVE			1	1
COLL-NON-FATAL	2		2	4
E 8TH AVE / CUMBERLAND ST	2			2
SHERBROOKE ST / E 8TH AVE			1	1
YORK ST / E 8TH AVE			1	1
DR WH/PROH-CCC		1		1
CUMBERLAND ST / RICKMAN PL		1		1
DRIVING COMPLNT	1			1
MCKAY ST / E 8TH AVE	1			1
DRV DISQ/SUS-PRV		2		2
E 10TH AVE / MASSEY ST		1		1
E 8TH AVE / MCKAY ST		1		1
FAIL STOP (CCC)	1	2	2	5

Primary UCR	2023	2024	2025	Total
CUMBERLAND ST / E 8TH AVE	1		1	2
E 10TH AVE / CUMBERLAND ST		1		1
E 8TH AVE / RICHMOND ST			1	1
RICHMOND ST / E 8TH AVE		1		1
FAIL STOP-PROV	2	1	2	5
200 BLOCK E 8TH AVE			1	1
348 E 8TH AVE	1			1
900 BLOCK LADNER ST	1			1
E 10TH AVE / CARIBOO RD			1	1
E 8TH AVE / CUMBERLAND ST		1		1
TRF-OTH MOVE	10	13	10	33
100 BLOCK E 10TH AVE		1		1
100 BLOCK E 8TH AVE		1	1	2
200 BLOCK E 8TH AVE	1			1
300 BLOCK CHURCHILL AVE			1	1
300 BLOCK E 8TH AVE	2			2
800 BLOCK CUMBERLAND ST		1		1
800 BLOCK YORK ST	1			1
900 BLOCK CUMBERLAND ST			1	1
99 BLOCK E 8TH AVE		1		1
CHERRY ST / E 8TH AVE			1	1
CUMBERLAND ST / E 8TH AVE	1	2		3
E 10TH AVE / CUMBERLAND ST	1	1	1	3
E 10TH AVE / MASSEY ST			1	1
E 8TH AVE / CUMBERLAND ST		5	2	7
E 8TH AVE / RICHMOND ST	2			2
E 8TH AVE / YORK ST			1	1
MASSEY ST / CHURCHILL AVE			1	1
RICHMOND ST / E 8TH AVE	2	1		3
TRF-OTH MUNCIPL			1	1
100 RICKMAN PL			1	1
TRF-OTH NON-MOVE		4	3	7
200 BLOCK E 10TH AVE		1		1
200 BLOCK E 8TH AVE		1		1
300 BLOCK E 10TH AVE			1	1
300 BLOCK E 8TH AVE			1	1
500 BLOCK E 10TH AVE		1		1
CUMBERLAND ST / E 8TH AVE			1	1
E 10TH AVE / CUMBERLAND ST		1		1
Total	26	29	32	87

COLL - DMGE < 10000.	Collision with Damage under \$10,000 value
COLL - DMGE > 10000.	Collision with Damage over \$10,000 value
COLL - NON - FATAL	Collision with non-fatal injuries
DR - WH / PROH - CCC	Driving while prohibited
Driving Complnt	Some form of Driving Compliant (likely minor in nature)
DRV DISQ / SUS-PRV	Driving while disqualified or suspended – provincial offence
FAIL Stop	Failing to stop for police or after an accident
TRF - OTH MOVE	Moving traffic offence (i.e. speeding)
TRF -OTH NON- MOVE	Non-Moving traffic offence (i.e. no driver's license)





MASSEY VICTORY HEIGHTS

Massey Victory Heights Residents Association recognizes and acknowledges the Qayqayt First Nation, as well as all Coast Salish peoples, on whose traditional and unceded territories we live, we learn, we play and we do our work

- Home
- Advocacy
- Contact Us
- About Us
- Sponsors
- Meetings
- Events
- Newsletter
- Media
- Sign Capper
- Forms
- Parks
- Little Libraries

Massey Victory Heights Residents Association Advocating On Local Neighbourhood Issues

Click individual Title Bars Below For Details on Each Issue

Active Transportation Plan (Bicycle Routes)

Neighbourhood Lighting Upgrade

Replies from the City

March 12 2026 Special Workshop #2 Update
[Workshop Update](#)

Nov 10, 2025 City Council's endorsed next steps

- 1) Next steps to entail staff's exploration to rehabilitate and reb for the use as a feature in an area of Massey Victory Heights, in decorative poles & fixtures, with new poles & fixtures in a simila market.
- 2) Staff to consult with the MVHRA regarding the repositioning combination with the newly selected fixtures of similar style in character.

o Link to discussion during Nov 10 /25 Council's workshop and 2 ([click here](#))

Neighbourhood Lighting Upgrade

October 1 2025 Heritage Assesment Report

[Memo To Community Heritage Commission](#)
Consultant Report [Massey Victory Heights Streetlights](#)

September 3 2025 Update-City Workshop

City workshop with Massey Victory Heights Residents
Link to [summary](#) of the evening's discussion

August 24th Arborist, Diamond Head Consulting, Summary

Diamond Head Consulting has reviewed the proposed plans for the street lighting upgrade, including new lampposts and underground conduit installations. Refer to the appended Tree Management Plans for locations and recommendations addressing potential conflicts with existing trees:

- **Lamppost Conflicts:** Several proposed lampposts are in direct conflict with city-owned and off-site trees. Minor adjustments to their locations are recommended to avoid root zone impacts.
- **Conduit Alignment Conflicts:** Portions of the proposed conduit alignment pass through boulevard areas



MASSEY VICTORY HEIGHTS

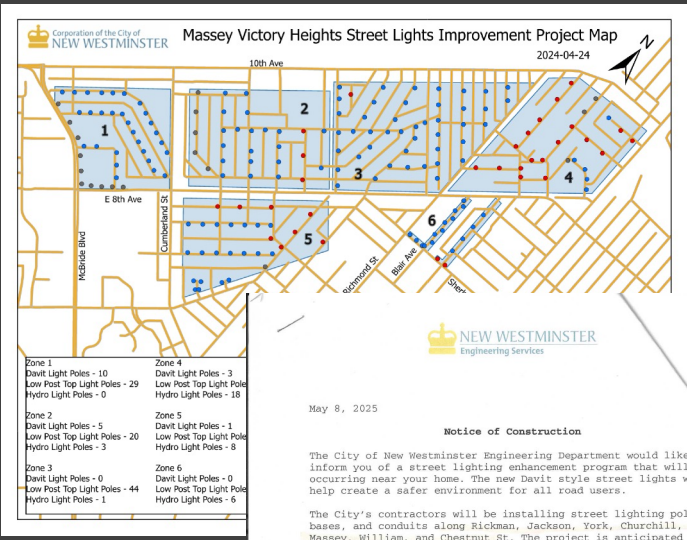

NEW WESTMINSTER
Engineering Services

May 8, 2025

Notice of Construction

The City of New Westminster Engineering Department would like to inform you of a street lighting enhancement program that will be occurring near your home. The new Davit style street lights will help create a safer environment for all road users.

The City's contractors will be installing street lighting poles, bases, and conduits along Rickman, Jackson, York, Churchill, Massey, William, and Chestnut St. The project is anticipated to start in May and continue until the end of September, 2025. The exact starting location will be determined by the contractor.



MASSEY VICTORY HEIGHTS

An opportunity have your say regarding light standards in Massey Victory Heights:
This Wednesday

As part of New Westminster's Massey Victory Heights Street Lighting Replacement project, the City is hosting a workshop to discuss the heritage values of the existing streetlights in the Massey-Victory Heights neighbourhood. We'll begin by exploring what "heritage values" are and how they're identified, then share the history of the neighbourhood and its streetlights. Then together, we'll explore and identify the specific heritage values of these streetlights as part of a Heritage Values Assessment requested by City Council.

See "Projects On The Go New Westminster" for more details on this project
Date: September 3, 2025
Time: 7:00pm - 9:00pm
Location: Imanovick Aquatic and Community Centre (65 E Sixth Ave) Multipurpose Room 2

New Westminster

Heritage Values Assessment Report

Massey Victory Heights Streetlights

October 2025

Schueck

Milestone events that followed the original Notice of Construction letter sent to Area 1 and 2 residents.

- Temporary closure of the parking lane in front of a given property.
 - Trenching and conduit installation within city boulevard and road crossings.
 - Two-way traffic the roads are anticipated to be maintained, but delays may occur.
- Landscaping fronting your property within the City right-of-way may be impacted by construction. The City will take steps to try and avoid landscape removal; however, in certain cases, it may be deemed necessary. Prior to removal, the resident will be contacted.
- For more information and the latest project updates please visit www.newwestcity.ca/roadworks
- If there are concerns regarding this project please contact Yongwon Song at ysong@newwestcity.ca or 604-329-7167.



PBX ENGINEERING

MASSEY VICTORY HEIGHTS STREET LIGHTING PROGRAM

City of New Westminster

EXISTING STREET LIGHTING INFRASTRUCTURE

- **Direct burial conductors**
 - Safety concern
 - Difficult to locate source of outage
- **High Pressure Sodium (HPS) fixtures**
 - High energy usage
 - Low (CRI) Colour Rendering Index (est. 20-30)
- **Typical existing street lighting:**
 - Heritage decorative style poles with HPS post top fixtures
 - 45m spacing, single sided
 - 4.5m height
 - Warm colour temperature (est. 2000-2700K)
 - Davit style poles with HPS cobrahead fixtures
 - 60m spacing, single sided
 - 7.6m height
 - Warm colour temperature (est. 2200-2700K)

Heritage Decorative Pole Post Top Fixture

Standard Davit Pole Cobrahead Fixture

PBX ENGINEERING

Meeting Topics

- 1) PBX / CNW New Design of latest layout with new streetlights
- 2) Review of Base options
- 3) Lamp 'cage' finishes/colours and related lamp details
- 4) Review of placeholder locations of 5 restored heritage streetlights along Churchill

"Lamp"



"Pole"



"Base"



S-OSP OmniScape

LED Urban Post Top with LEDgine technology



Massey Victory Heights
Aug 2025 Courtesy J.
Schueck



The Sylvania Twist Pak
Post Top Refractor
Model. Courtesy Jim



S-OSP TCC with Skirt

Transitional configuration with skirt and 'TTT' top, shown here in red box, was preferred by majority vote.



S-OSP TTT with Skirt

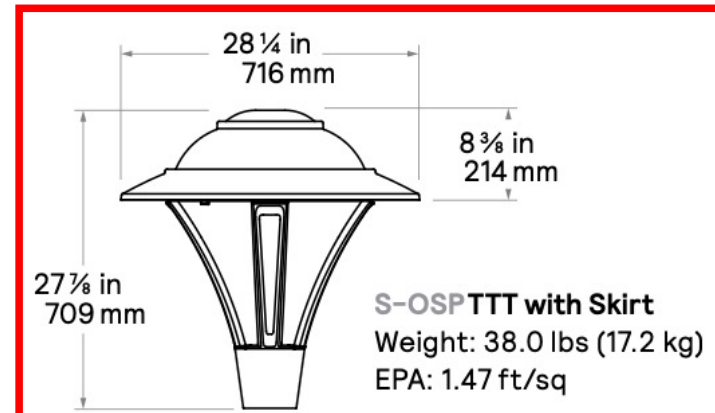

Size Chart



1.866.874.8889

novapole.com



MASSEY VICTORY HEIGHTS

PBX brought to the meeting actual full-size decorative bases allowing residents the opportunity to see the physical size and the detail that could be compared to the existing ones.

Those in adjacent red boxes had been previously selected by residents during the first Dec 17th workshop.



Aurora

Two piece base, with access door
 Material: Cast Aluminum
 Finishing: Powder Coated
 Part #: 101-04-4AURB2-F
 Height: 762mm 2' 6"
 Bottom O.D.: 438mm 1' 6 7/8"
 Top I.D.: 171mm 6 1/4"

Pole Cross Sections

The pole shaft can be tapered or straight with round section.





TIME TO REGISTER FOR:



21st annual Garage sale , Deadline to register Friday April 24th

Adjournment

